

Selection diagram

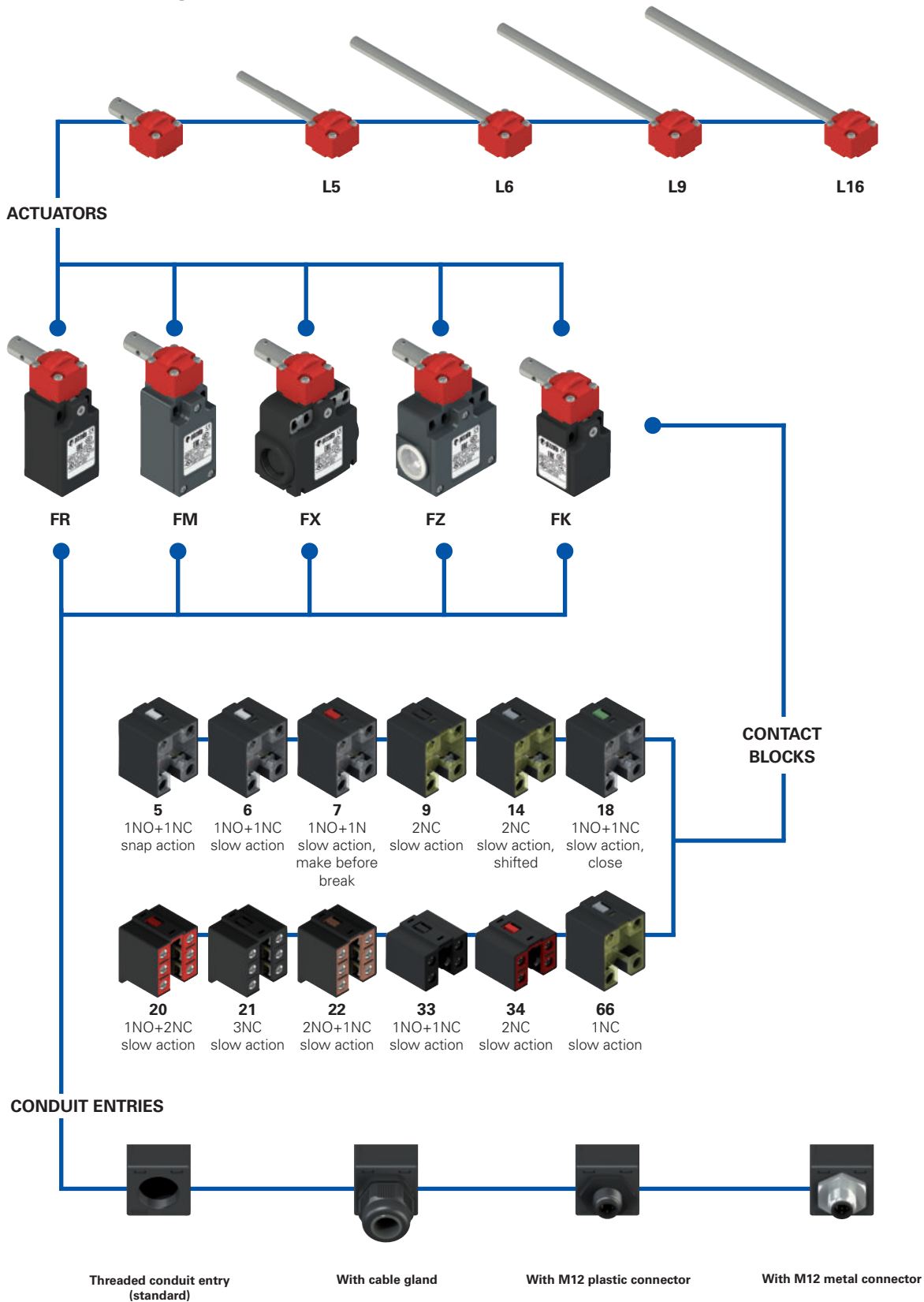

—●— product options

**Code structure****Attention!** The feasibility of a code number does not mean the effective availability of a product. Please contact our sales office.

article
options
options

FR 1896-XGL16M2K70T6

Housing	
FR	technopolymer, one conduit entry
FM	metal, one conduit entry
FX	technopolymer, two conduit entries
FZ	metal, two conduit entries

Contact blocks	
5	1NO+1NC, snap action
6	1NO+1NC, slow action
7	1NO+1NC, slow action, make before break
9	2NC, slow action
14	2NC, slow action, shifted
18	1NO+1NC, slow action, close
20	1NO+2NC, slow action
21	3NC, slow action
22	2NO+1NC, slow action
33	1NO+1NC, slow action
34	2NC, slow action
66	1NC, slow action

External metallic parts	
	zinc-plated steel (standard)
X	stainless steel

Contact type	
	silver contacts (standard)
G	silver contacts with 1 µm gold coating
G1	silver contacts, 2.5 µm gold coating (not for contact blocks 20, 21, 22, 33, 34)

Ambient temperature	
	-25°C ... +80°C (standard)
T6	-40°C ... +80°C

Pre-installed cable glands or connectors	
	no cable gland or connector (standard)
K23	cable gland for cables Ø 6 ... 12 mm
...
K70	M12 plastic connector, 4-pole
...

For the complete list of possible combinations please contact our technical department.

Threaded conduit entry	
M2	M20x1.5 (standard)
M1	M16x1.5 (FR-FX housing only)
	PG 13.5
A	PG 11 (FR-FX housing only)

Actuator design	
	actuator with hole (standard)
L5	Ø8x69 mm, tapered Ø6.9
L6	Ø8x120 mm
L9	Ø8x140 mm
L16	Ø8.7x165 mm, stainless steel

article
options
options

FK 3396-XGL16M1K24T6

Housing	
FK	technopolymer, one conduit entry

Contact blocks	
33	1NO+1NC, slow action
34	2NC, slow action

External metallic parts	
	zinc-plated steel (standard)
X	stainless steel

Contact type	
	silver contacts (standard)
G	silver contacts with 1 µm gold coating

Ambient temperature	
	-25°C ... +80°C (standard)
T6	-40°C ... +80°C

Pre-installed cable glands	
	no cable gland (standard)
K24	cable gland for cables Ø 5 ... 10 mm
K28	cable gland for cables Ø 3 ... 7 mm

Threaded conduit entry	
M1	M16x1.5 (standard)
	PG11

Actuator design	
	actuator with hole (standard)
L5	Ø8x69 mm, tapered Ø6.9
L6	Ø8x120 mm
L9	Ø8x140 mm
L16	Ø8.7x165 mm, stainless steel

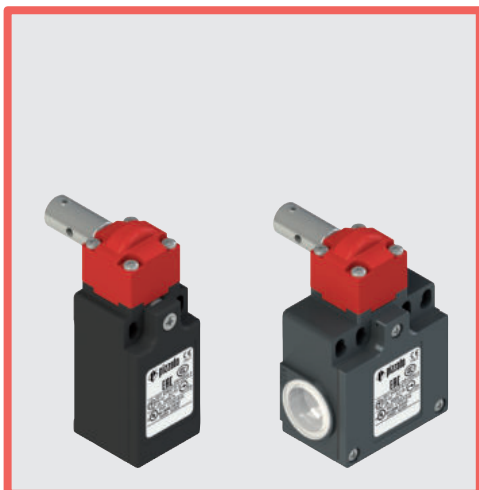

Main features

- Metal housing or technopolymer housing, from one to two conduit entries
- Protection degree IP67
- 12 contact blocks available
- Versions with M12 connector
- Versions with gold-plated silver contacts
- Versions with stainless steel external metallic parts

Quality marks:



IMQ approval:	EG610
UL approval:	E131787
CCC approval:	2007010305230013
EAC approval:	RU C-IT.YT03.B.00035/19

Technical data

Housing

FR, FX and FK series housing made of glass fibre reinforced technopolymer, self-extinguishing, shock-proof and with double insulation: □
 FM and FZ series: metal housing, baked powder coating.
 FR, FM series: one threaded conduit entry: M20x1.5 (standard)
 FK series: one threaded conduit entry: M16x1.5 (standard)
 FX series: two knock-out threaded conduit entries: M20x1.5 (standard)
 FZ series: two threaded conduit entries: M20x1.5 (standard)
 Protection degree: IP67 acc. to EN 60529 with cable gland of equal or higher protection degree

General data

SIL (SIL CL) up to:	SIL 3 acc. to EN 62061
Performance Level (PL) up to:	PL e acc. to EN ISO 13849-1
Mechanical interlock, not coded:	type 1 acc. to EN ISO 14119
Safety parameters:	
B_{100} :	5,000,00 for NC contacts
Mission time:	20 years
Ambient temperature:	-25°C ... +80°C (standard) -40°C ... +80°C (T6 option)
Max. actuation frequency:	3600 operating cycles/hour
Mechanical endurance:	1 million operating cycles
Max. actuation speed:	180°/s
Min. actuation speed:	2°/s
Tightening torques for installation:	see page 341
Wire cross-sections and wire stripping lengths:	see page 357

In compliance with standards:

IEC 60947-5-1, IEC 60947-1, IEC 60204-1, EN ISO 14119, EN ISO 12100, IEC 60529, EN 50581, UL 508, CSA 22.2 No.14.

Approvals:

EN 60947-5-1, UL 508, CSA 22.2 No.14, GB/T14048.5-2017.

Compliance with the requirements of:

Machinery Directive 2006/42/EC, EMC Directive 2014/30/EU, RoHS Directive 2011/65/EU.

Positive contact opening in conformity with standards:

IEC 60947-5-1, EN 60947-5-1.

⚠ If not expressly indicated in this chapter, for correct installation and utilization of all articles see the instructions given on pages 337 to 350.

	Electrical data	Utilization category																
without connector	Thermal current (I_{th}): 10 A Rated insulation voltage (U): 500 Vac 600 Vdc 400 Vac 500 Vdc (contact blocks 20, 21, 22, 33, 34) Rated impulse withstand voltage (U_{imp}): 6 kV 4 kV (contact blocks 20, 21, 22, 33, 34) Conditional short circuit current: 1000 A acc. to EN 60947-5-1 Protection against short circuits: type aM fuse 10 A 500 V Pollution degree: 3	Alternating current: AC15 (50±60 Hz) <table> <tr> <td>U_e (V)</td> <td>250</td> <td>400</td> <td>500</td> </tr> <tr> <td>I_e (A)</td> <td>6</td> <td>4</td> <td>1</td> </tr> </table> Direct current: DC13 <table> <tr> <td>U_e (V)</td> <td>24</td> <td>125</td> <td>250</td> </tr> <tr> <td>I_e (A)</td> <td>3</td> <td>0.55</td> <td>0.3</td> </tr> </table>	U_e (V)	250	400	500	I_e (A)	6	4	1	U_e (V)	24	125	250	I_e (A)	3	0.55	0.3
U_e (V)	250	400	500															
I_e (A)	6	4	1															
U_e (V)	24	125	250															
I_e (A)	3	0.55	0.3															
with M12 connector, 4 and 5-pole	Thermal current (I_{th}): 4 A Rated insulation voltage (U): 250 Vac 300 Vdc Protection against short circuits: type gG fuse 4 A 500 V Pollution degree: 3	Alternating current: AC15 (50±60 Hz) <table> <tr> <td>U_e (V)</td> <td>24</td> <td>120</td> <td>250</td> </tr> <tr> <td>I_e (A)</td> <td>4</td> <td>4</td> <td>4</td> </tr> </table> Direct current: DC13 <table> <tr> <td>U_e (V)</td> <td>24</td> <td>125</td> <td>250</td> </tr> <tr> <td>I_e (A)</td> <td>3</td> <td>0.55</td> <td>0.3</td> </tr> </table>	U_e (V)	24	120	250	I_e (A)	4	4	4	U_e (V)	24	125	250	I_e (A)	3	0.55	0.3
U_e (V)	24	120	250															
I_e (A)	4	4	4															
U_e (V)	24	125	250															
I_e (A)	3	0.55	0.3															
with M12 connector, 8-pole	Thermal current (I_{th}): 2 A Rated insulation voltage (U): 30 Vac 36 Vdc Protection against short circuits: type gG fuse 2 A 500 V Pollution degree: 3	Alternating current: AC15 (50±60 Hz) <table> <tr> <td>U_e (V)</td> <td>24</td> </tr> <tr> <td>I_e (A)</td> <td>2</td> </tr> </table> Direct current: DC13 <table> <tr> <td>U_e (V)</td> <td>24</td> </tr> <tr> <td>I_e (A)</td> <td>2</td> </tr> </table>	U_e (V)	24	I_e (A)	2	U_e (V)	24	I_e (A)	2								
U_e (V)	24																	
I_e (A)	2																	
U_e (V)	24																	
I_e (A)	2																	



Description



These safety switches are designed to monitor gates or guards that safeguard dangerous parts of machines without inertia. They are very sensitive, open the contacts after few degrees of rotation and immediately send the stop signal. The head, which can be turned in 90° steps, enables installation in multiple positions. Available with technopolymer or metal housings, with protection degree IP67. The special design allows it to be used even under operating conditions in which dust and dirt could inhibit the operation of normal safety switches with separate actuator.

Head with variable orientation

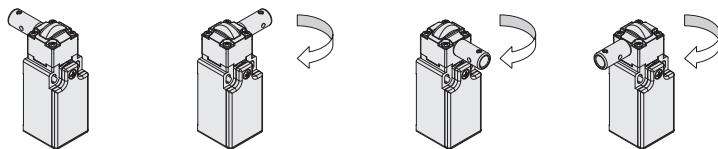

For all switches, the head can be adjusted in 90° steps after removing the four fastening screws. This allows you to use the same switch on both right- and left-facing door fronts.

Protection degree IP67

IP67 These devices are designed to be used in the toughest environmental conditions and they pass the IP67 immersion test acc. to EN 60529. They can therefore be used in all environments where maximum protection degree of the housing is required.

Extended temperature range

-40°C These devices are also available in a special version suitable for an ambient operating temperature range from -40°C up to +80°C.

They can therefore be used for applications in cold stores, sterilisers and other equipment with low temperature environments. The special materials used to produce these versions retain their characteristics even under these conditions, thereby expanding the installation possibilities.

Application examples

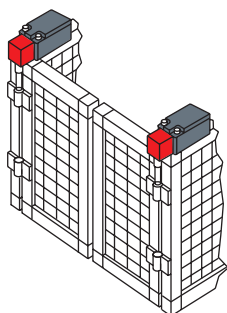

Safety switches for hinges, mounting on double door

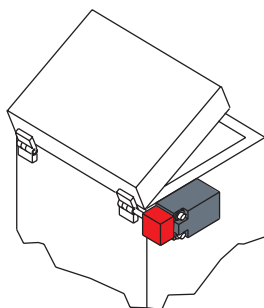

Safety switch for hinges, mounting outside the safety guard

Adjustable switching point



When installing the device, the contact switching point can be adjusted over the entire 360° range. By fixing the stud screw, it is possible to check the correct setting of the activation angle and quickly and easily adjust it if necessary. Once adjustment is complete, you can render the device tamper-proof against commonly used tools using the supplied lock pin.

Features approved by IMQ

Rated insulation voltage (U _i):	500 Vac 400 Vac (for contact blocks 20, 21, 22, 33, 34)
Conventional free air thermal current (I _n):	10 A
Protection against short circuits:	type aM fuse 10 A 500 V
Rated impulse withstand voltage (U _{imp}):	6 kV 4 kV (for contact blocks 20, 21, 22, 33, 34)
Protection degree of the housing:	IP67
MV terminals (screw terminals)	
Pollution degree:	3
Utilization category:	AC15
Operating voltage (U _e):	400 Vac (50 Hz)
Operating current (I _e):	3 A
Forms of the contact element:	Zb, Y+Y, Y+Y+X, Y+Y+Y, Y+X+X
Positive opening contacts on contact blocks	5, 6, 7, 9, 14, 18, 20, 21, 22, 33, 34, 66.
In compliance with standards:	EN 60947-1, EN 60947-5-1, fundamental requirements of the Low Voltage Directive 2014/35/EU.

Please contact our technical department for the list of approved products.

Features approved by UL

Electrical Ratings:	Q300 pilot duty (69 VA, 125-250 V dc) A600 pilot duty (720 VA, 120-600 V ac)
Environmental Ratings:	Types 1, 4X, 12, 13
Use 60 or 75 °C copper (Cu) conductor and wire size range 12, 14 AWG, stranded or solid. The terminal tightening torque of 7.1 lb in (0.8 Nm).	
For FR, FX, FK series: the hub is to be connected to the conduit before the hub is connected to the enclosure.	

Please contact our technical department for the list of approved products.

Contact type:
R = snap action
L = slow action
LO = slow action make before break
LS = slow action shifted

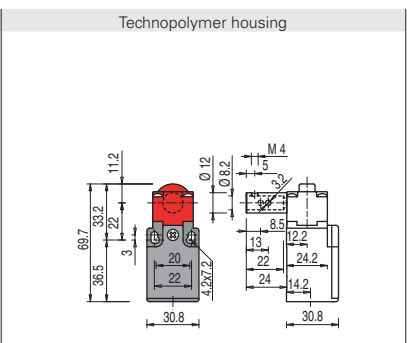
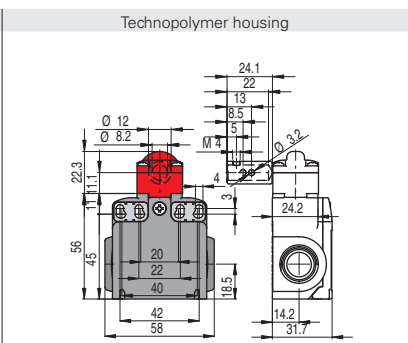
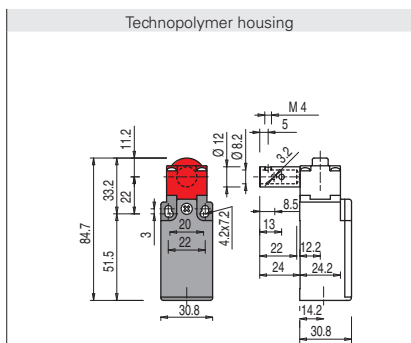

Contact blocks

5	R	FR 596-M2	⊕	1NO+1NC	FX 596-M2	⊕	1NO+1NC	/
6	L	FR 696-M2	⊕	1NO+1NC	FX 696-M2	⊕	1NO+1NC	/
7	LO	FR 796-M2	⊕	1NO+1NC	FX 796-M2	⊕	1NO+1NC	/
9	L	FR 996-M2	⊕	2NC	FX 996-M2	⊕	2NC	/
14	LS	FR 1496-M2	⊕	2NC	FX 1496-M2	⊕	2NC	/
18	L	FR 1896-M2	⊕	1NO+1NC	FX 1896-M2	⊕	1NO+1NC	/
20	L	FR 2096-M2	⊕	1NO+2NC	FX 2096-M2	⊕	1NO+2NC	/
21	L	FR 2196-M2	⊕	3NC	FX 2196-M2	⊕	3NC	/
22	L	FR 2296-M2	⊕	2NO+1NC	FX 2296-M2	⊕	2NO+1NC	/
33	L	FR 3396-M2	⊕	1NO+1NC	FX 3396-M2	⊕	1NO+1NC	FK 3396-M1 ⊕ 1NO+1NC
34	L	FR 3496-M2	⊕	2NC	FX 3496-M2	⊕	2NC	FK 3496-M1 ⊕ 2NC
66	L	FR 6696-M2	⊕	1NC	FX 6696-M2	⊕	1NC	/
Actuating force		0.15 Nm (0.4 Nm ⊕)		0.15 Nm (0.4 Nm ⊕)		0.15 Nm (0.4 Nm ⊕)		
Travel diagrams		page 344 - group 9		page 344 - group 9		page 344 - group 9		

Contact type:
R = snap action
L = slow action
LO = slow action make before break
LS = slow action shifted

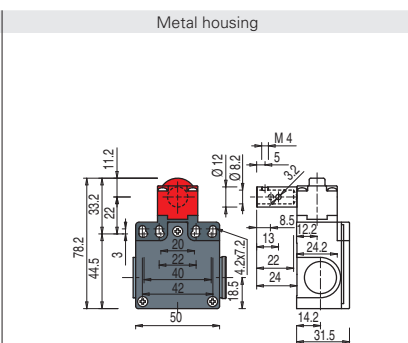
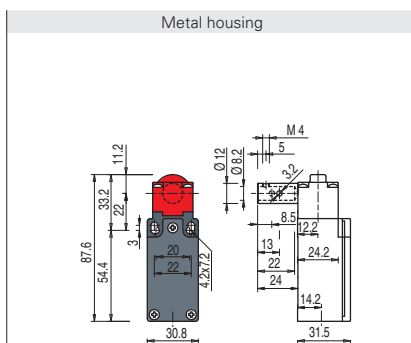

Contact blocks

5	R	FM 596-M2	⊕	1NO+1NC	FZ 596-M2	⊕	1NO+1NC
6	L	FM 696-M2	⊕	1NO+1NC	FZ 696-M2	⊕	1NO+1NC
7	LO	FM 796-M2	⊕	1NO+1NC	FZ 796-M2	⊕	1NO+1NC
9	L	FM 996-M2	⊕	2NC	FZ 996-M2	⊕	2NC
14	LS	FM 1496-M2	⊕	2NC	FZ 1496-M2	⊕	2NC
18	L	FM 1896-M2	⊕	1NO+1NC	FZ 1896-M2	⊕	1NO+1NC
20	L	FM 2096-M2	⊕	1NO+2NC	FZ 2096-M2	⊕	1NO+2NC
21	L	FM 2196-M2	⊕	3NC	FZ 2196-M2	⊕	3NC
22	L	FM 2296-M2	⊕	2NO+1NC	FZ 2296-M2	⊕	2NO+1NC
33	L	FM 3396-M2	⊕	1NO+1NC	FZ 3396-M2	⊕	1NO+1NC
34	L	FM 3496-M2	⊕	2NC	FZ 3496-M2	⊕	2NC
66	L	FM 6696-M2	⊕	1NC	FZ 6696-M2	⊕	1NC
Actuating force		0.15 Nm (0.4 Nm ⊕)		0.15 Nm (0.4 Nm ⊕)			
Travel diagrams		page 344 - group 9		page 344 - group 9			

Dimensional drawings for actuators

Option	Drawing
L5	
L6	
L9	
L16	

Adjustment of the switching point

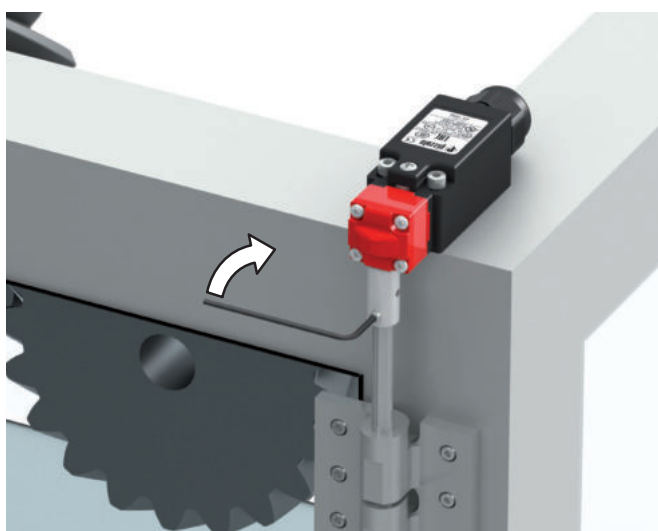

Temporary locking of the actuator (stud screw provided).

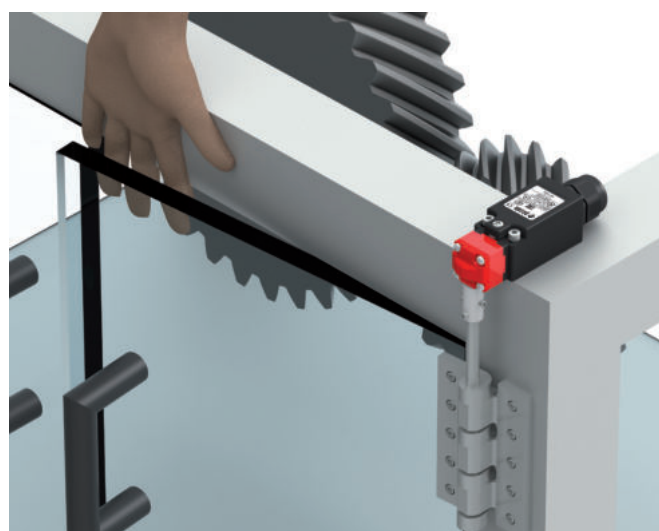

Verify the switching point according to EN ISO 13857 and recalibrate if necessary.

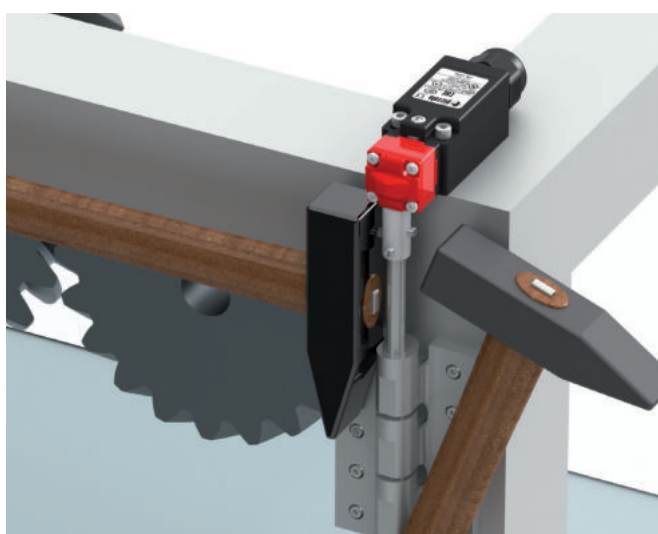

Pin the switch (pin is provided).